

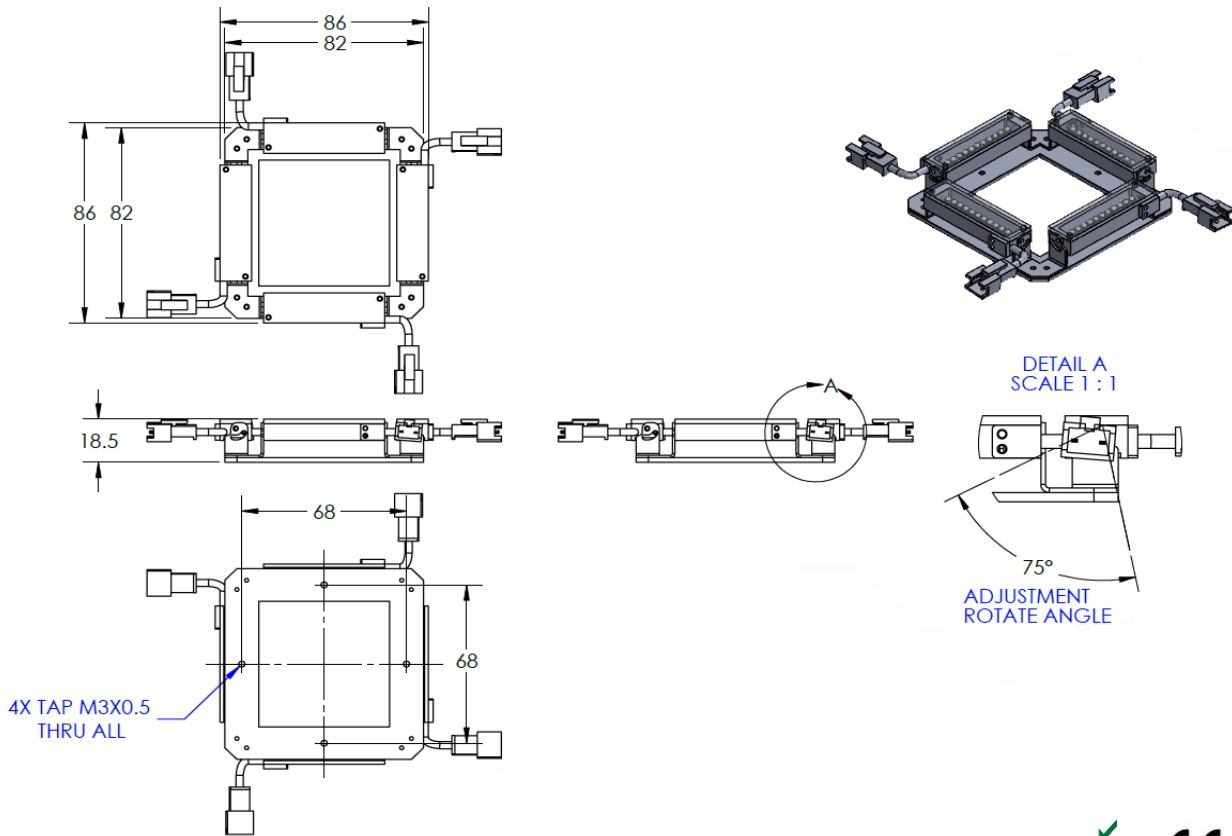

ILLUMINATOR DATA (ID)

LBMQ-00-040-2-B-24V

Lighting Dimension



| Mechanical Information | |
|---------------------------|------------------------------|
| Casing Material | Aluminium |
| Storage Temperature Range | Temp 0-45°C, Humidity 20-85% |
| Weight | 116 g |
| Length / Outer Diameter | 86 mm |
| Width / Inner Diameter | 86 mm |
| Thickness / Height | 18.5 mm |



ILLUMINATOR DATA-

LBMQ-00-040-2-B-24V

| Optical Information | | | | |
|--|--|---|-------------|-----|
| Part Number | LBMQ-00-040-2-B-24V | | | |
| LED Color | BLUE | | | |
| Wavelength | (nm) | 470 | | |
| Intensity (±15) | (Lux) | TBA | TBA | TBA |
| Working Distance | (mm) | 10 | 20 | 30 |
| Illumination (number of row) | 2 | | | |
| Illumination Active Area | | | | |
| Active Length / Outer Dia. | (mm) | 50 | | |
| Active Width / Inner Dia. | (mm) | 9.1 | | |
| Emission angle | (deg.) | 0 | | |
| Eye Safety Class (IEC62471) | II | | | |
| *CHROMATICITY TABLE | | | | |
| | | | | |
| Electrical Information | | | | |
| Lighting Supply Voltage (constant voltage mode) | 24V ± 2% | | | |
| Continuous Current | (mA) | 208 | | |
| Power Consumption | (W) | 4.992 | | |
| Lighting casing temperature, Operating after 60 minutes | °C | 48.2 | | |
| | | | | |
| Strobe Mode Specification | | | | |
| Pulse Operation | YES | | | |
| Max. Lighting Supply Voltage (Constant voltage power supply) | (V) | Pulsing at 24VDC to 48VDC, 0-10% Duty Cycle Recommended at 36VDC | | |
| Pulse Current, (Max. 10msec) (Constant current power supply) | (mA) | 624 | | |
| Max. Trigger Pulse Duration | (msec) | 10 | | |
| Duty Cycle | 0-10% | | | |
| | | | | |
| Additional Information | | | | |
| Additional Cooling Method | Attached to machine part for better heat dissipation | | | |
| Intensity Controller Selection | ANG, SD, ST & SDA series | | | |
| CE Conformity | YES | | | |
| RoHS Compliance | YES | | | |
| | | | | |
| Connection | | | | |
| Connector Type (Default): | JST SMR-03V | | | |
| Cable Length out from lighting : | (mm) | 500 | | |
| Pin Configuration : | Pin | Signal | Cable Color | |
| | 1 | LED + | RED | |
| | 2 | N.C. | --- | |
| | 3 | LED - | WHITE | |
|  | | | | |
| | | | | |
| Application | | | | |
| Illumination Type | Direct Illumination | | | |
| Application Use | General illumination, label inspection, character inspection, code recognition | | | |



VISION CONSULTANCY
MAKING THE UNSEEN VISIBLE

Thank you for downloading this document from
www.machine-vision-shop.com

If you have any questions, you need help composing the
right package for your application or do you want to order?

Feel free to contact us via e-mail at sales@vision-consultancy.nl or visit our webshop.

Our vision experts are happy to help you.



Natascha Overhof



Christian Cromptoets



VISION CONSULTANCY

Robert Schumandomein 2
6229 ES Maastricht
The Netherlands

+31 (0) 438 522 651

sales@vision-consultancy.nl
www.machine-vision-shop.com

Scan me to visit
[machine-vision-shop](http://machine-vision-shop.com)

